

# BERTH 551

MAX DRAUGHT (MW):	9,3 M	MAX/MIN MANIFOLD HEIGHT	
MAX LOA:	150 M	ABOVE WATERLINE (MW):	13/3 M
MAX BREADTH:	N/A	QUAY DECK HEIGHT (MW):	3 M
UKC:	0.5 M	MAX DISTANCE FROM DRAUGHT	
MIN PARALLELL BODY:	20 M	LIMIT TO HARDARM HFO No. 1 CONNECTION:	67,4 M
MIN FREEBOARD (MW):	N/A	MAX DISPLACEMENT:	N/A
		MAX SPEED:	N/A

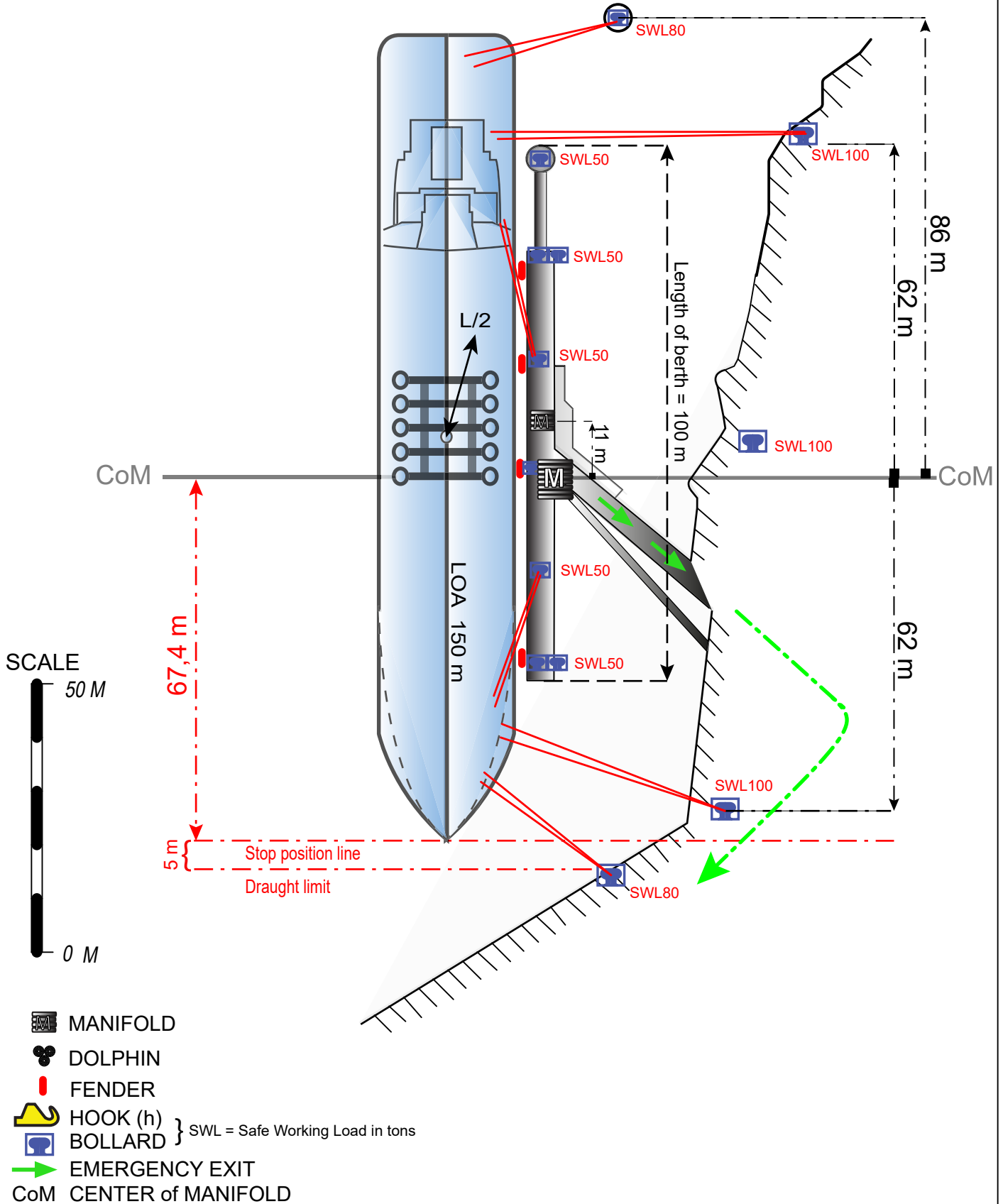

	 N	BERTH DIRECTION 016° / 196°	<b>MOORING PLAN SKARVIK BERTH 551</b>				BERTH / DRAWING NO BERTH551	APPROVED BY CL
		DATE 2020-07-09	DRAWN MAFLOBE	SCALE 				

HARD ARM No.	SIZE OF CONN.	PRODUCT	COMPANY	MAX PRESSURE BAR	MAX LOADING/DISCHARGING CAPACITY M3/H
--------------	---------------	---------	---------	------------------	---------------------------------------

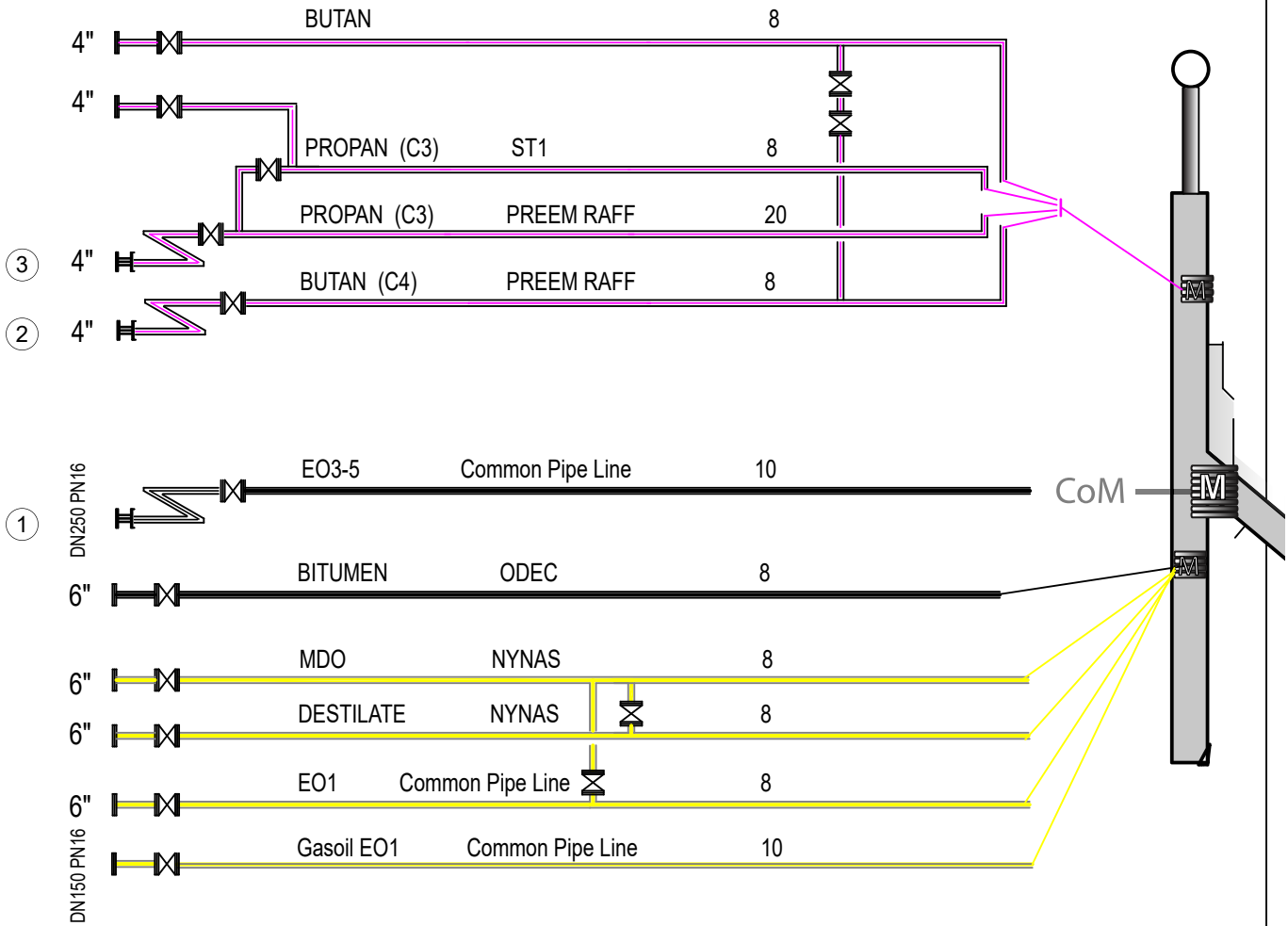

- ① = Hard arm No.
- = Hard arm symbol
- = Hose symbol

Bunkers available by barge  
Fresh water available

	 N	BERTH DIRECTION 016° / 196°	<b>MANIFOLD ARRANGEMENT SKARVIK BERTH 551</b>			
			DATE 2019-10-31	DRAWN MAFLOBE	SCALE 	BERTH / DRAWING NO BERTH551